

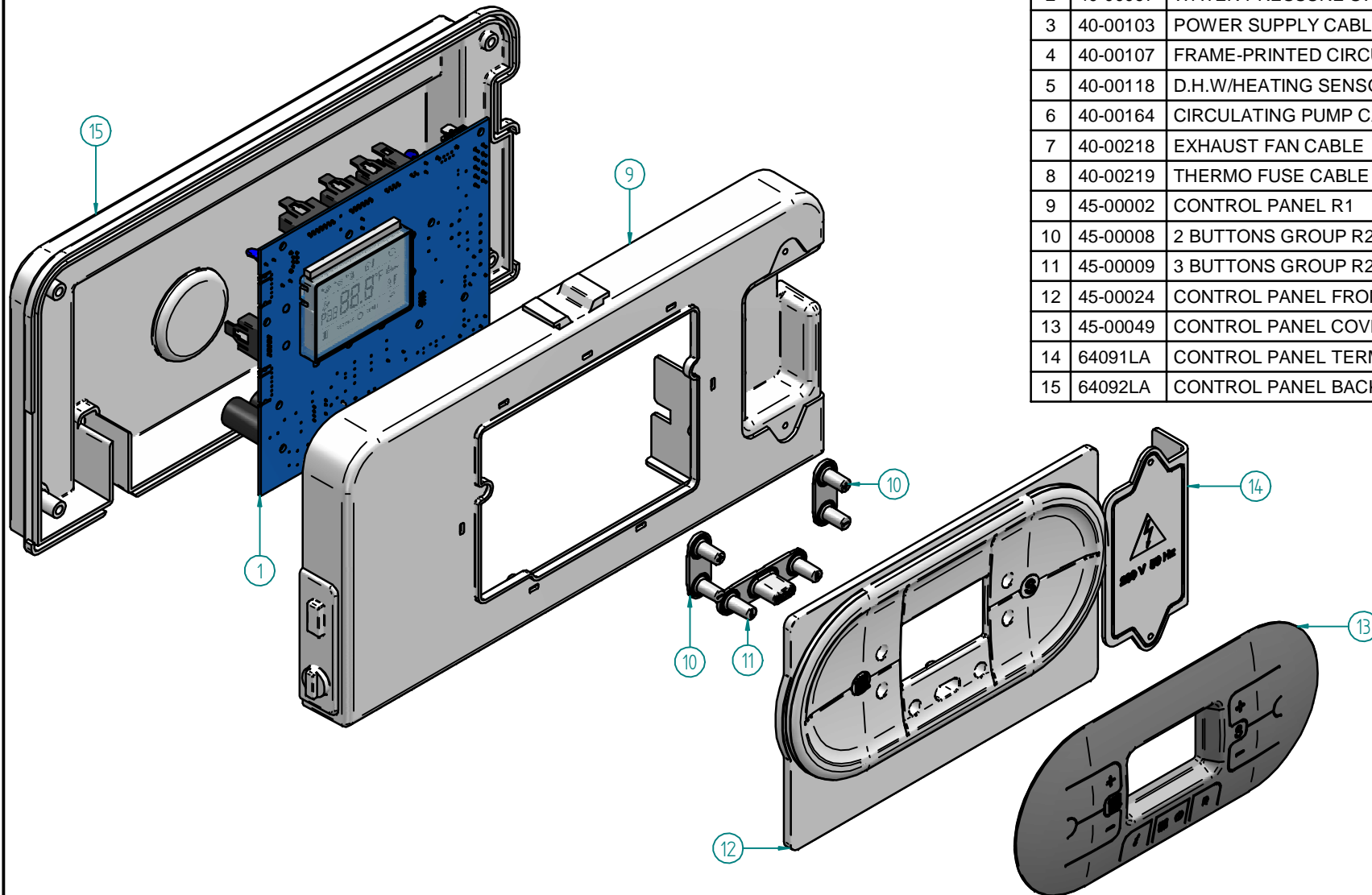

N°	Code	Description	Qty
1	15-00996	TRANSFORMER FIXING PLATE	1
2	15-01038	FRAME	1
3	15-01040	FRAME RIGHT/LEFT HOOK	2
4	15-01042	CONDESATE SIPHON FIXING PLATE	1
5	15-01043	CONTROL PANEL LEFT SIDE BRACKET	1
6	15-01044	CONTROL PANEL RIGHT SIDE BRACKET	1
7	15-01046	CASING LEFT SIDE PANEL	1
8	15-01047	CASING RIGHT SIDE PANEL	1
9	15-01048	EXPANSION VESSEL FIXING BRACKET	1
10	15-01062	ROOM-SEAL CHAMBER TOP	1
11	15-01105	EXPANSION VESSEL BOTTOM BRACKET	1
12	15-01211	ROOM-SEAL CHAMBER BOTTOM	1
13	35-00081	CASING FRONT PANEL	1
14	35-00082	INSULATION FRONT PANEL	1
15	35-00083	INSULATION RIGHT/LEFT PANELS	2
16	35-00087	INSULATION ROOM-SEAL CHAMBER TOP	1
17	62011LP	HOLES CLOSING PLATE Ø100	2

Disegnatore	Rev.	data revisione	Autore revisione	Descrizione revisione
crislian.pozzaglin				
Modificato				
crislian.pozzaglin				
Data di creazione	Scala	Materiale	Sp.	Peso (Kg)
05/06/2015	155			4383.897
Note				
Descrizione completa R1K 18 COMBI-TECH MET - CS R2 GRIGIO				
 RADIANT BRUCIATORI s.p.a. 61025 Loc. Montelabbate (PS) - Via Pantanelli, 164 Tel. 0721/90791 (n. 4 linee r.a.) - Fax. 0721/9079299			Codice A991A182A101	Revisione 00



N°	Code	Description	Qty
1	40-00077	PRINTED CIRCUIT BOARD R2 PANEL	1
2	40-00097	WATER PRESSURE SWITCH CABLE	1
3	40-00103	POWER SUPPLY CABLE	1
4	40-00107	FRAME-PRINTED CIRCUIT BOARD CABLE	1
5	40-00118	D.H.W/HEATING SENSOR CABLE	1
6	40-00164	CIRCULATING PUMP CABLE INTMSL 12/6-1	1
7	40-00218	EXHAUST FAN CABLE	1
8	40-00219	THERMO FUSE CABLE	1
9	45-00002	CONTROL PANEL R1	1
10	45-00008	2 BUTTONS GROUP R2 PANEL	2
11	45-00009	3 BUTTONS GROUP R2 PANEL	1
12	45-00024	CONTROL PANEL FRONT COVER	1
13	45-00049	CONTROL PANEL COVER R1K GRAY	1
14	64091LA	CONTROL PANEL TERMINAL BOARD COVER OBLO' 1380062	1
15	64092LA	CONTROL PANEL BACK PLATE OBLO' - 138006	1

Disegnatore	Rev.	data revisione	Autore revisione	Descrizione revisione
crislian.pazzaqlin				
Modificato				
crislian.pazzaqlin				
Data di creazione	Scala	Materiale	Sp.	Peso (Kg)
05/06/2015	12			369,046
Note				
Descrizione completa CONTROL PANEL COMPLETE R1K 24-28-34				
 RADIANT BRUCIATORI s.p.a. 61025 Loc. Montelabbate (PS) - Via Pantanelli, 164 Tel. 0721/90791 (n. 4 linee r.a.) - Fax. 0721/9079299				Codice 41-00126
				Revisione 00

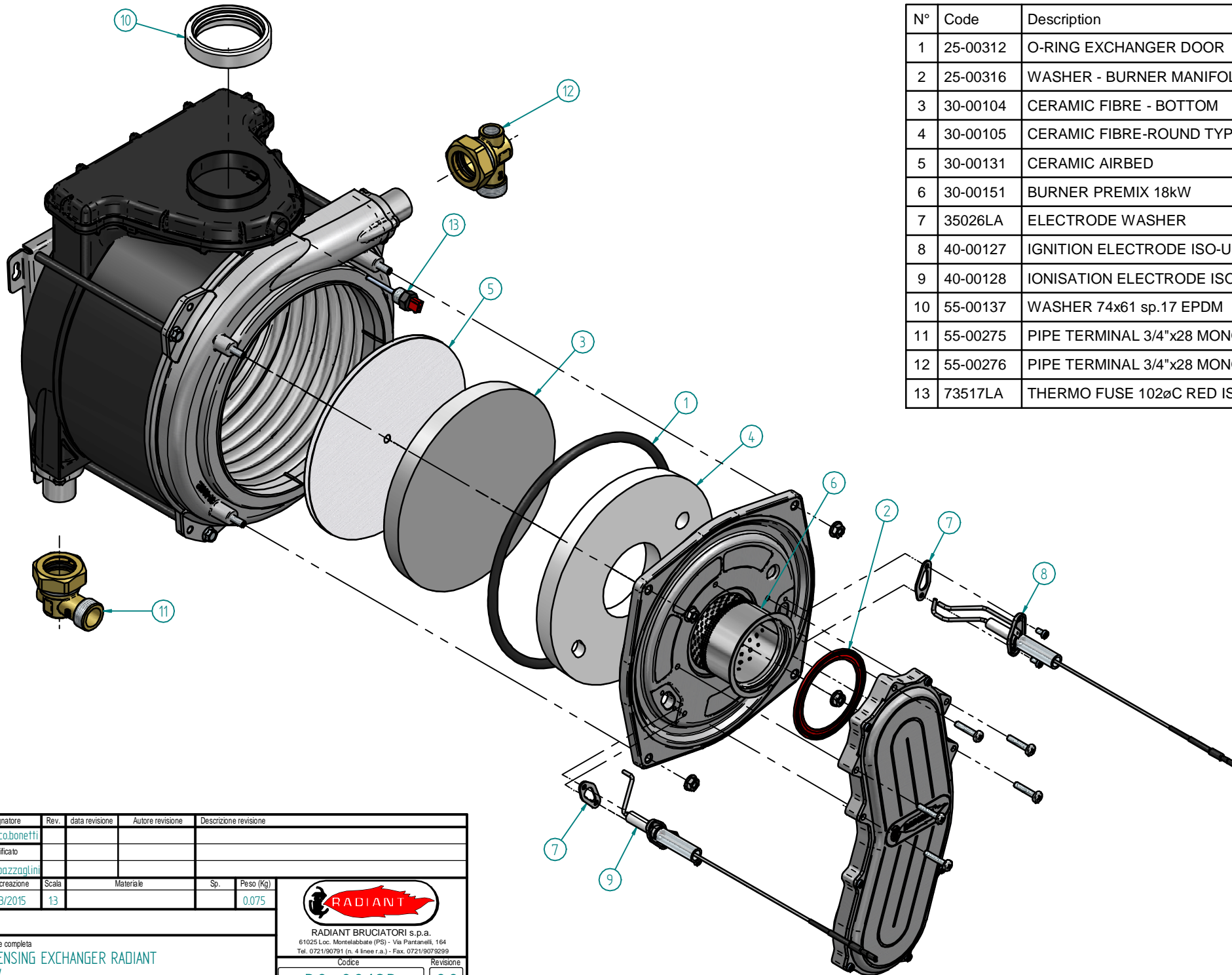

N°	Code	Description	Qty
1	25-00312	O-RING EXCHANGER DOOR	1
2	25-00316	WASHER - BURNER MANIFOLD	1
3	30-00104	CERAMIC FIBRE - BOTTOM	1
4	30-00105	CERAMIC FIBRE-ROUND TYPE 20SP.	1
5	30-00131	CERAMIC AIRBED	1
6	30-00151	BURNER PREMIX 18kW	1
7	35026LA	ELECTRODE WASHER	2
8	40-00127	IGNITION ELECTRODE ISO-USA.w/CABLE	1
9	40-00128	IONISATION ELECTRODE ISO-USA w/CABLE	1
10	55-00137	WASHER 74x61 sp.17 EPDM	1
11	55-00275	PIPE TERMINAL 3/4"x28 MONOTHERMIC	1
12	55-00276	PIPE TERMINAL 3/4"x28 MONOTHERMIC	1
13	73517LA	THERMO FUSE 102°C RED ISOTHERM. 1/4"	1

Disegnatore	Rev.	data revisione	Autore revisione	Descriptione revisione
francescobonetti				
Modificato				
crislianpazzaglini				
Data di creazione	Scala	Materiale	Sp.	Peso (Kg)
05/03/2015	13			0.075
Note				
Descrizione completa				
CONDENSING EXCHANGER RADIANT				
24kW				
 RADIANT BRUCIATORI s.p.a. 61025 Loc. Montebbate (PS) - Via Pantanelli, 164 Tel. 0721/90791 (n. 4 linee r.a.) - Fax. 0721/9079299		Codice 30-00193	Revisione 00	